

Particular Features:

Corner hinge

Suitable for steel panels with a thickness of 1,0 mm to 2,2 mm

Hinge pin available in three types

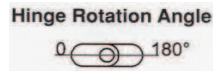
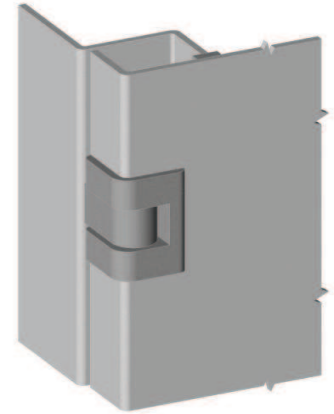

Application:

Small electric panels

Version	Materials / Finish	Part-No.
	Zamak® / chrome 1,0 mm - 1,2 mm panel thickness	HC10ED-*-T15
	Zamak® / black 1,0 mm - 1,2 mm panel thickness	HC10EH-*-T15
	Zamak® / chrome 1,5 mm - 2,0 mm panel thickness	HC10ED-*-T22
	Zamak® / black 1,5 mm - 2,0 mm panel thickness	HC10EH-*-T22

add version to article number

* Version	PIN	Materials / Finish
*A		Poliasetal (Delrin)
*B		steel / zinc plated
*C		steel / zinc plated

Dimensions and Hole Preparation

