

Particular Features:

- For doors with a bent of 20 mm or 24 mm
- Frame part screwed on
- Door part welded-on
- Left hand and right hand application is possible
- Note: Bolts are not given

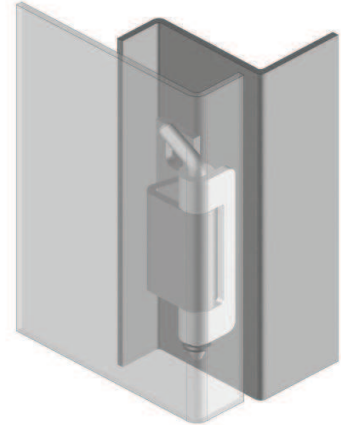

Application:

Electric panels, machinery covers

Version	Materials / Finish	Part-No.
	body: steel / zinc plated welding part: copper plated 20 mm bent	HI10AG-T1
	body: steel / zinc plated welding part: copper plated 24 mm bent	HI10AG-T2

Dimensions and Hole Preparation

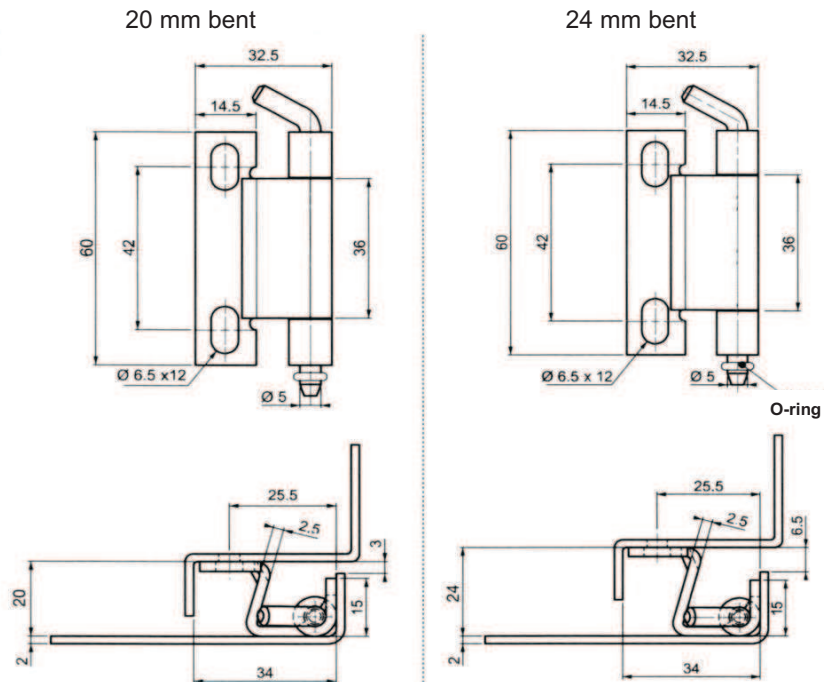

Particular Features:

- For doors with a bent of 20 mm or 24 mm
- Frame part screwed on
- Door part welded-on
- Left hand and right hand application is possible
- Note: Bolts are not given

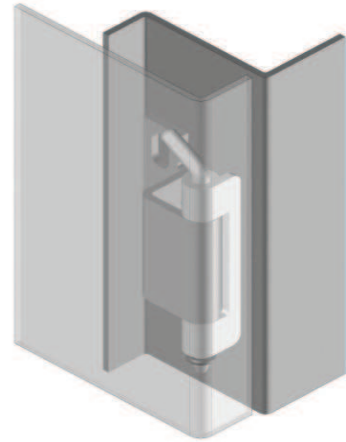
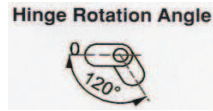

Application:

Electric panels, machinery covers

Version	Materials / Finish	Part-No.
	body: steel / zinc plated welding part: copper plated 20 mm bent	HI10AG-T3
	body: steel / zinc plated welding part: copper plated 24 mm bent	HI10AG-T4

Dimensions and Hole Preparation

