

Particular Features:

- For doors with a bent of 18 mm
- Frame part screwed on
- Door part screwed or welded-on
- Left hand and right hand application is possible
- Note: Bolts are given

Hinge Rotation Angle

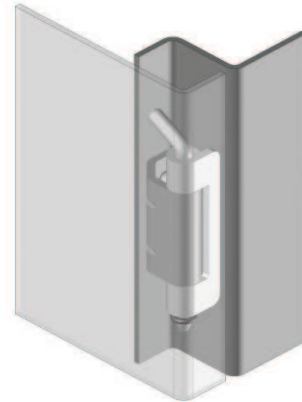

Application:

Electric panels, machinery covers

Version	Materials / Finish	Part-No.
	body: steel / zinc plated welding part: copper plated 18 mm bent	HI30AG-T1
	stainless steel 18 mm bent	HI30B-T1

Dimensions and Hole Preparation

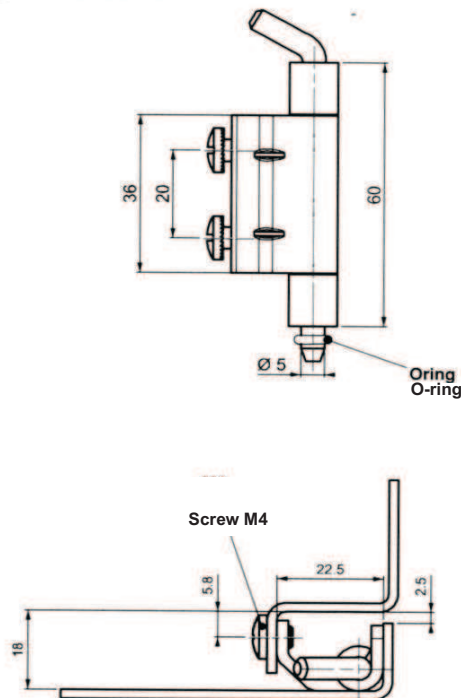

Particular Features:

For doors with a bent of 18,5 mm

Frame part screwed on

Door part is mounted by nut to welded stud on door

Left hand and right hand application is possible

Note: Bolts are given

Hinge Rotation Angle

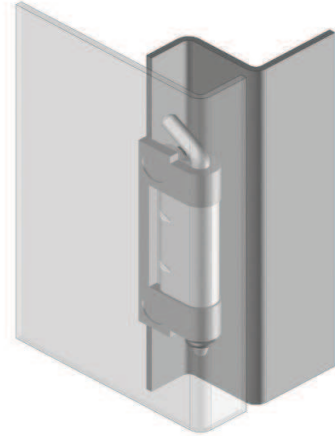

Application:

Electric panels, machinery covers

Version	Materials / Finish	Part-No.
	steel / zinc plated 18,5 mm bent	HI30AG-T2

Dimensions and Hole Preparation

