

**Particular Features:**

Lock is designed to act like a knob  
IP65 is standard for L30A

**Application:**

Machinery covers, electric panels

**Selection Instructions:**

1. Select housing from page 19
2. Select drive from page 20
3. Select cam from page 21 or 22

**Part Number Example**

L30A I - ED - 03ED - 33AG

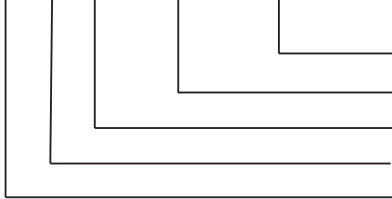

Type, Material and Finish Cam  
Type, Material and Finish Driver  
Material and Finish Housing  
IP65 (standard for CAM L30A and L30B, not available for L30C)  
Series





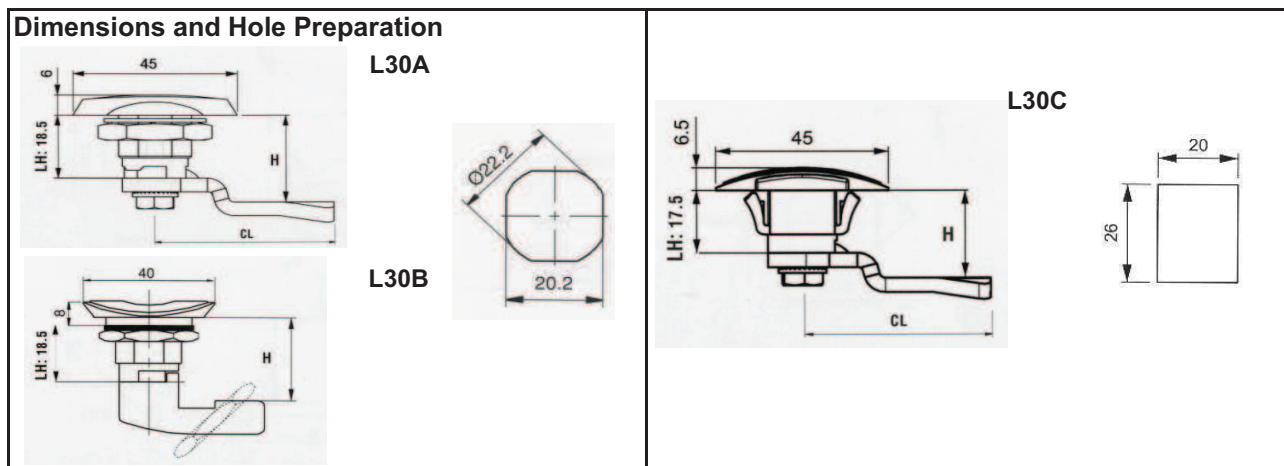









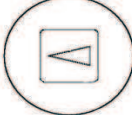
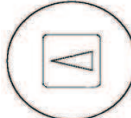

Version	Materials / Finish	Part-No.
	Polyamid Black PA6 GFR30 IP65	L30AI-K-*
	Polyamid Black PA6 GFR30 IP65	L30BI-K-*
	Polyamid Black PA6 GFR30	L30C-K-*



\* Order examples for complete part numbers see page 23

## Drivers

<b>3mm Double Bit</b> 		<b>5mm Double Bit</b> 		<b>Slot 2X4</b> 		<b>Slot</b> 	
<b>Material / Finish</b>	<b>Part-No.</b>	<b>Material / Finish</b>	<b>Part-No.</b>	<b>Material / Finish</b>	<b>Part-No.</b>	<b>Material / Finish</b>	<b>Part-No.</b>
Zamak® Chrome	01ED	Zamak® Chrome	02ED	Zamak® Chrome	03ED	Zamak® Chrome	04ED
Zamak® Black	01EH	Zamak® Black	02EH	Zamak® Black	03EH	Zamak® Black	04EH
Polyamid Black	02K	Polyamid Black	02K	Polyamid Black	03K		
<b>6mm Square</b> 		<b>7mm Square</b> 		<b>8mm Square</b> 		<b>Railway</b> 	
<b>Material / Finish</b>	<b>Part-No.</b>	<b>Material / Finish</b>	<b>Part-No.</b>	<b>Material / Finish</b>	<b>Part-No.</b>	<b>Material / Finish</b>	<b>Part-No.</b>
Zamak® Chrome	05ED	Zamak® Chrome	06ED	Zamak® Chrome	07ED	Zamak® Chrome	08ED
Zamak® Black	05EH	Zamak® Black	06EH	Zamak® Black	07EH	Zamak® Black	08EH
Polyamid Black	05K	Polyamid Black	06K	Polyamid Black	07K		
<b>8mm Square Slot</b> 		<b>7mm Triangular</b> 		<b>8mm Triangular</b> 		<b>9mm Triangular</b> 	
<b>Material / Finish</b>	<b>Part-No.</b>	<b>Material / Finish</b>	<b>Part-No.</b>	<b>Material / Finish</b>	<b>Part-No.</b>	<b>Material / Finish</b>	<b>Part-No.</b>
Zamak® Chrome	09ED	Zamak® Chrome	10ED	Zamak® Chrome	11ED	Zamak® Chrome	12ED
Zamak® Black	09EH	Zamak® Black	10EH	Zamak® Black	11EH	Zamak® Black	12EH
		Polyamid Black	10K	Polyamid Black	11K	Polyamid Black	12K
<b>8mm Inner Hexagon</b> 		<b>10mm Inner Hexagon</b> 		<b>6mm Inner Square</b> 		<b>Torx T30</b> 	
<b>Material / Finish</b>	<b>Part-No.</b>	<b>Material / Finish</b>	<b>Part-No.</b>	<b>Material / Finish</b>	<b>Part-No.</b>	<b>Material / Finish</b>	<b>Part-No.</b>
Zamak® Chrome	13ED	Zamak® Chrome	14ED	Zamak® Chrome	15ED	Zamak® Chrome	16ED
Zamak® Black	13EH	Zamak® Black	14EH	Zamak® Black	15EH	Zamak® Black	16EH

## Cams with Stopper

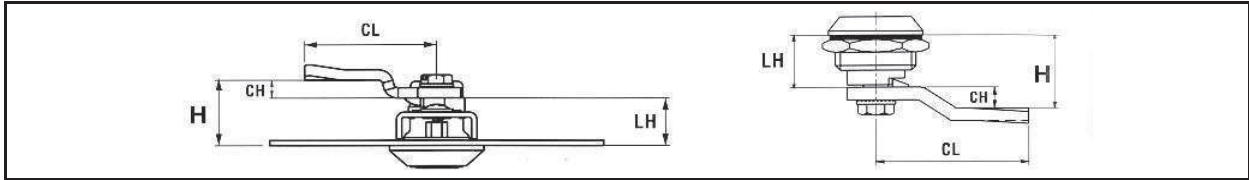

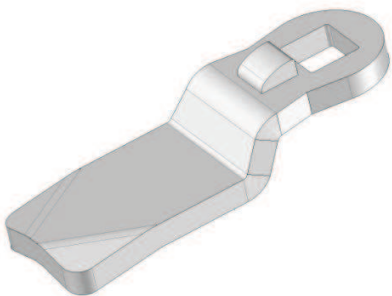
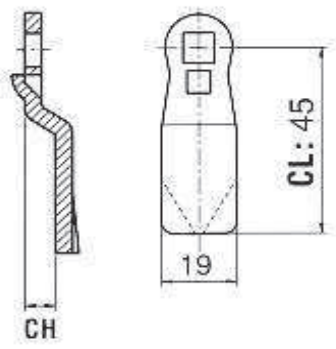
	H	CH	CL	Materials / Finish	Part-No.
<b>Version A</b>    	4,5	-14	45	Steel / Zinc plated	01AG
	6,5	-12	45	Steel / Zinc plated	02AG
	8,5	-10	45	Steel / Zinc plated	03AG
	10,5	-8	45	Steel / Zinc plated	04AG
	12,5	-6	45	Steel / Zinc plated	05AG
	14,5	-4	45	Steel / Zinc plated	06AG
	16,5	-2	45	Steel / Zinc plated	07AG
	18,5	0	45	Steel / Zinc plated	08AG
				Stainless Steel	08BP
	20,5	2	45	Stainless Steel	09BP
	21,5	3	45	Steel / Zinc plated	10AG
				Stainless Steel	10BP
	22,5	4	45	Steel / Zinc plated	11AG
				Stainless Steel	11BP
	24,5	6	45	Steel / Zinc plated	12AG
				Stainless Steel	12BP
	26,5	8	45	Steel / Zinc plated	13AG
				Stainless Steel	13BP
	28,5	10	45	Steel / Zinc plated	14AG
				Stainless Steel	14BP
	30,5	12	45	Steel / Zinc plated	15AG
			Stainless Steel	15BP	
32,5	14	45	Steel / Zinc plated	16AG	
34,5	16	45	Steel / Zinc plated	17AG	
36,5	18	45	Steel / Zinc plated	18AG	
			Stainless Steel	18BP	
38,5	20	45	Steel / Zinc plated	19AG	
40,5	22	45	Steel / Zinc plated	20AG	
42,5	24	45	Steel / Zinc plated	21AG	

**Cams with Stopper**

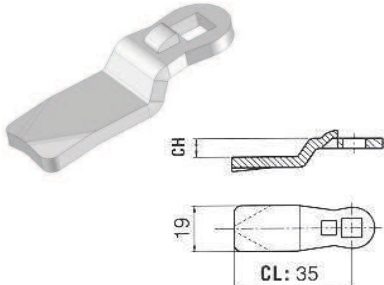
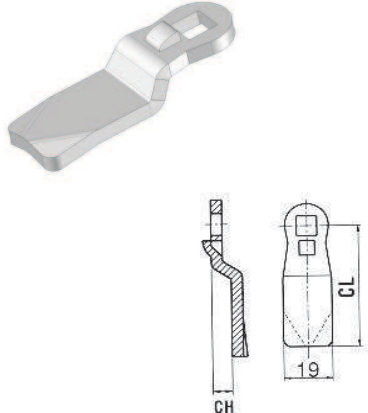
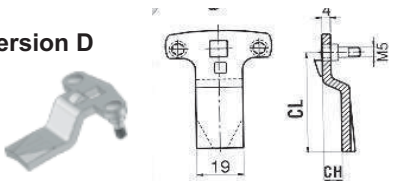
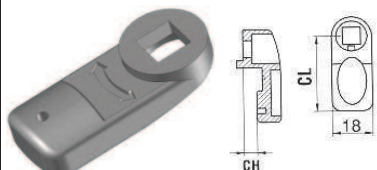
	H	CH	CL	Materials / Finish	Part-No.
<b>Version B</b> 	16,5	-2	35	Steel / Zinc plated	22AG
	18,5	0	35	Steel / Zinc plated	23AG
	20,5	2	35	Steel / Zinc plated	24AG
	22,5	4	35	Steel / Zinc plated	25AG
	24,5	6	35	Steel / Zinc plated	26AG
	25,5	7	35	Steel / Zinc plated	27AG
	28,5	10	35	Steel / Zinc plated	28AG
	44,5	26	35	Steel / Zinc plated	29AG
<b>Version C</b> 	18,5	0	29	Steel / Zinc plated	30AG
	18,5	0	38	Steel / Zinc plated	31AG
	18,5	0	66	Steel / Zinc plated	32AG
				Stainless Steel	32BP
	18,5	0	51	Steel / Zinc plated	33AG
	21,5	3	38	Steel / Zinc plated	34AG
	21,5	3	51	Steel / Zinc plated	35AG
	24,5	6	37	Steel / Zinc plated	36AG
	25,5	7	44	Steel / Zinc plated	37AG
	25,5	7	49	Steel / Zinc plated	38AG
				Stainless Steel	38BP
	28,5	10	48	Steel / Zinc plated	39AG
47,5	29	45	Steel / Zinc plated	40AG	
<b>Version D</b> 	18,5	0	51	Steel / Zinc plated	50AG
	25,5	7	49	Steel / Zinc plated	51AG
	30,5	12	46	Steel / Zinc plated	52AG
<b>Version E</b> 	14,5	-4	45	Polyamid Black	60K
	18,5	0	25	Polyamid Black	61K
	18,5	0	35	Polyamid Black	62K
	22,5	4	45	Polyamid Black	63K
	24,5	6	35	Polyamid Black	64K

## Order example

Spring, Nut and Screw are always part of the set, please order like the following examples



Housing plastic, selected from page 19

L30AI-K-\*

Drive 3mm double bit, Zamak® chrome,  
selected from page 20

01ED-

Cam Version A, steel zinc plated, CH = 14mm  
selected from page 21

16AG

### Complete part number

**L30AI-K-01ED-16AG**



Housing plastic, selected from page 19

L30C-K-\*

Drive 3mm double bit, Zamak® chrome,  
selected from page 20

01K-

Cam Version A, steel zinc plated, CH = 14mm  
selected from page 21

16AG

### Complete part number

**L30C-K-01K-16AG**