

Particular Features:

Specially designed internal spring provides 1 mm torsion

Application:

Electric panels, machinery covers

Selection Instructions:

1. Select housing from page 28
2. Select drive or knob from page 29
3. Select cam from page 29

Part Number Example

L50A - ED - 03ED - 33AG

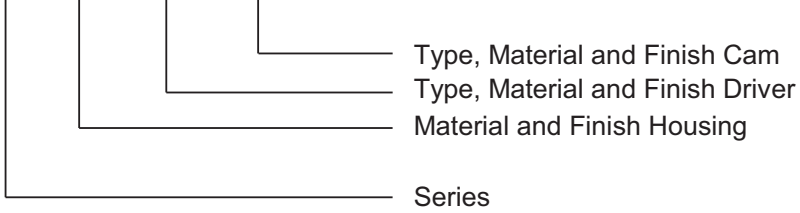

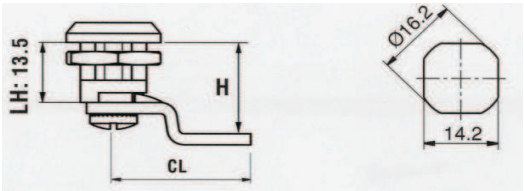
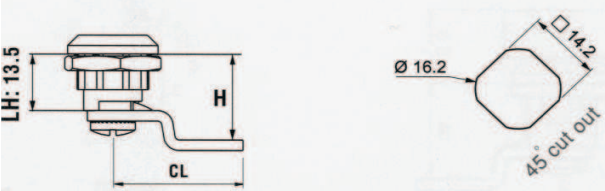

Housing

Version	Materials / Finish	Part-No.
	Zamak® DIN-EN1774-ZnAl4Cu1 chrome plated (CrVI-free) cut out standard	L50A-ED-*
	Zamak® DIN-EN1774-ZnAl4Cu1 chrome plated (CrVI-free) cut out 45°	L50B-ED-*
	Zamak® DIN-EN1774-ZnAl4Cu1 black coated (CrVI-free) cut out standard	L50A-EH-*
	Zamak® DIN-EN1774-ZnAl4Cu1 black coated (CrVI-free) cut out 45°	L50B-EH-*
	Polyamid Black PA6 GFR30 cut out standard	L50A-K-*
	Polyamid Black PA6 GFR30 cut out 45°	L50B-K-*

Dimensions and Hole Preparation L50A	L50B
	

* Order examples for complete part numbers see page 29

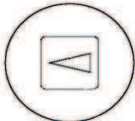
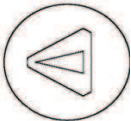
Drivers

Slot 2X4		6mm Square		7mm Triangular		Knob Type Y *	
							
Material / Finish	Part-No.	Material / Finish	Part-No.	Material / Finish	Part-No.	Material / Finish	Part-No.
03ED	Zamak® Chrome	05ED	Zamak® Chrome	10ED	Zamak® Chrome	19ED	Zamak® Chrome
03EH	Zamak® Black	05EH	Zamak® Black	10EH	Zamak® Black	19EH	Zamak® Black
03K	Polyamid Black	05K	Polyamid Black	10K	Polyamid Black	19K	Polyamid Black

* only with housing version A available

Cams

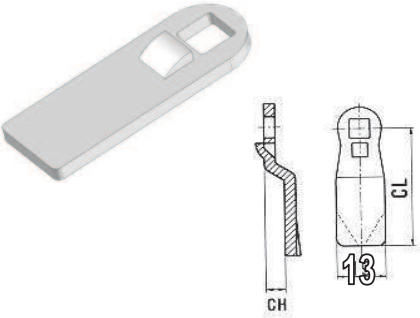
Version C	H	CH	CL	Materials / Finish	Part-No.
	7,5	-6	25	Steel / Zinc plated	50AG
	13,5	0	25	Steel / Zinc plated	51AG
	19,5	6	25	Steel / Zinc plated	52AG
	20,5	7	30	Steel / Zinc plated	53AG
	13,5	0	33	Steel / Zinc plated	54AG

Order example



Housing plastic, standard cut out,
selected from page 28

L50A-K-*

Drive 6mm square, Zamak® chrome,
selected from above

05ED-

Cam Version C, CH = 6 mm; CL 25 mm
selected from above

52AG

Complete part number

L50A-K-05ED-52AG