

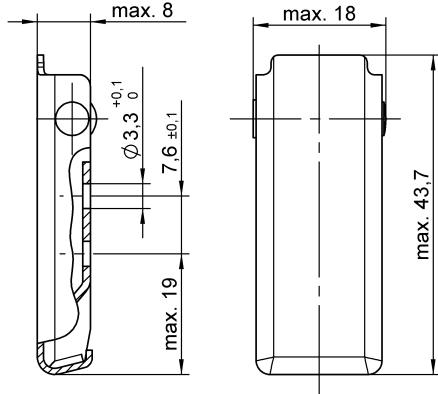



Max. tensile strength 445 N, working load 220 N
 Handle conceals all interior parts and strike
 Self-compensating spring steel drawhook
 Low profile

Style	Dimensions	Materials / Finish	Part No.
Self-compensating spring steel drawhook 		Stainless steel	V95L07-1-1BC
Self-compensating spring steel drawhook 		Steel / chrome-plated Interior parts: Steel / zinc-plated, CrVI-free, clear passivation	V95L15-1BD

Strike

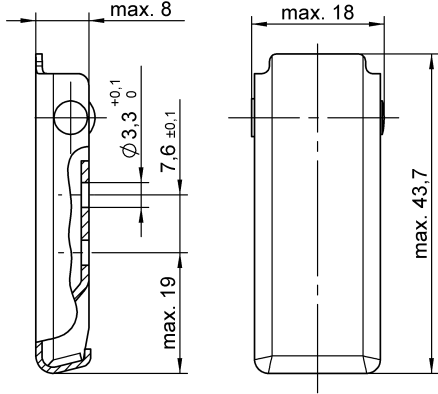
Style	Dimensions	Materials / Finish	Part No.
		Stainless steel	V95H07-1-1BP

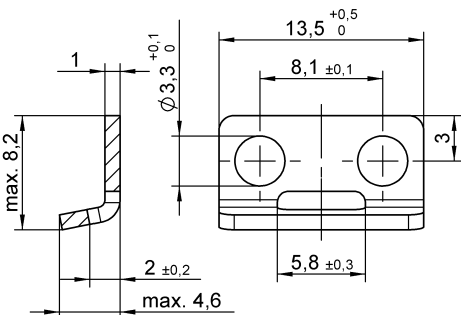
Dimensions

Spring steel drawhook tension latch / strike

